



Automatic Grease Removal Unit

INSTALLATION, OPERATIONS
AND MAINTENANCE MANUAL

Models D1, D2, D3, D4, D5



MANUFACTURED BY FM ENVIRONMENTAL

www.greaseguardian.com



CONTENTS

Product Overview	2
How it Works	3
Dimensions & Specifications	4
Installation	5
Health, Safety and Efficiency	6
Time Control Setting	7
Engineer Settings:	
Commissioning and Service	12
User Maintenance.....	14
Tri-Monthly Servicing.....	15
Troubleshooting	16
Warranty	18

APPENDICES

1. D1 to D4 wiring diagram (230V)...	20
2. D1 to D4 wiring diagram (110V)...	21
3. D5 wiring diagram.....	22

THE GREASE GUARDIAN D1-D5 SERIES

The FM Environmental Grease Guardian series automatic grease removal unit (GRU) is a totally engineered system for separating free floating grease and oils from drain water flows. The separated grease and oils are trapped within the stainless steel tank and are automatically recovered by the system. Only the “cleaned” water is allowed to pass through the system into the drain lines. Each unit also separates solid food waste into a removable basket. The Grease Guardian can be used in a wide variety of applications from restaurants and food processing operations to many types of industrial operations. Appliances that can be directly connected include utensils sinks, pre-rinse sinks, combination ovens, and wok cookers.

Use of the Grease Guardian assures that costly sewer surcharges and fines are minimised or eliminated through efficient separation and removal of the grease and oil. In addition, rapidly escalating pumping and disposal costs, which are associated with conventional grease traps or interceptors are also reduced or eliminated. When properly operated the recovered grease and oils are virtually water free so they can be collected by a local rendering Company or recycler.

HOW IT WORKS

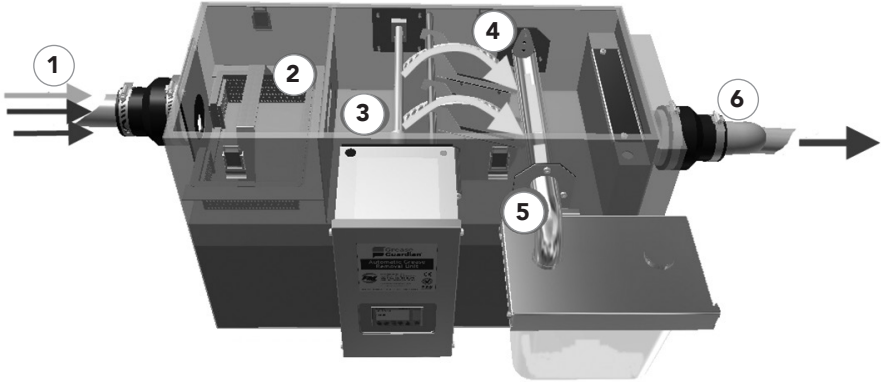

- 1 Grease, solids and wastewater from the kitchen enters the Grease Guardian.
- 2 Solid food waste is caught in a removable strainer.
- 3 The grease passes into the middle chamber through slots in the baffle wall where it remains trapped. With the assistance of a heater the grease separates from the wastewater and rises to the surface.
- 4 The liquefied grease adheres to the rotating skimming wheels/drum.
- 5 The grease passes down a scraper blade into a collection container where it can be removed and disposed hygienically.
- 6 The treated water exits under a baffle wall and through the outlet to drain.

PRODUCT DIMENSIONS & SPECIFICATION (240V)

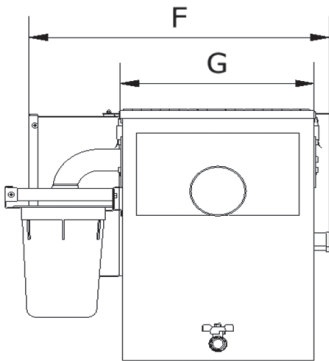
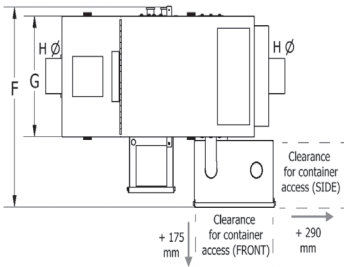
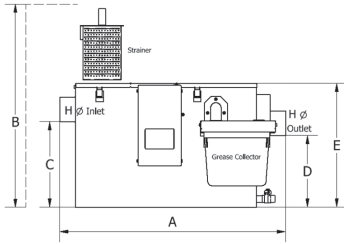

Right/Left Flow Optional.
All dimensions to be mirrored

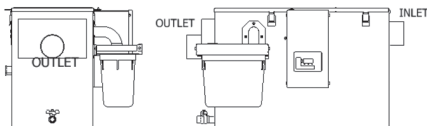

Model	(mm)							
	A	B	C	D	E	F	G	H
D1	640	500	150	150	330	520	310	60
D2	720	620	225	210	410	520	310	60
D3	840	705	310	260	450	520	310	90
D4	922	710	295	230	450	520	310	115
D5	1422	920	405	335	560	592	310	115

Model	D1	D2	D3	D4	D5
Hydraulic Flow <i>l/second</i>	0.75	1.25	1.75	2.25	3.5
Strainer Capacity, <i>litres</i>	3	4	8	10	14
Grease Collector Capacity, <i>litres</i>	3.5	4.5	4.5	4.5	11
Skimming Rate, <i>l/hr</i> Basic model	2	2	4	4	12
Max Skimming Rate, <i>l/hr</i> Upgraded (3 skimmers)	6	6	6	6	12

Casing Material (all units)	16 Gauge; 304 stainless steel; bright finish
Motor (all units)	25 Watt, 240V, 50 Hz 1.3µF capacitor
Heater D1, D2	600 Watt, 240V, Thermal cut-out inc.
Heater D3, D4	1000 Watt, 240V, Thermal cut-out inc.
Heater D5	2000 Watt, 240V, Thermal cut-out inc.
Controller (all units)	Programmable Logic Controller: Backlit display Inputs 240V AC Outputs 240V AC Battery back up

PRODUCT DIMENSIONS & SPECIFICATION (110V)

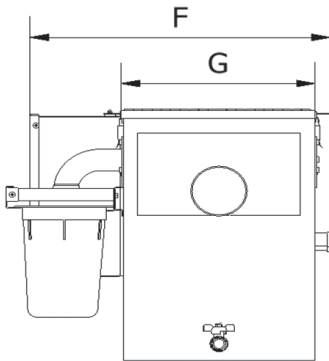
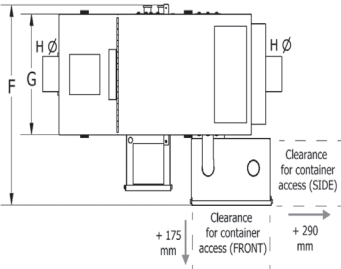
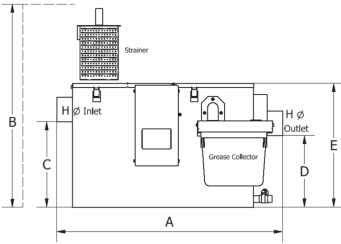

Right/Left Flow Optional.
All dimensions to be mirrored

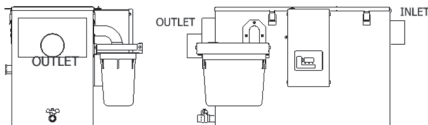

	Model (inches)							
	A	B	C	D	E	F	G	H
D1	25.2	19.7	5.9	5.9	13.0	20.5	12.2	2.0
D2	28.3	24.4	8.9	8.3	16.1	20.5	12.2	2.0
D3	33.1	27.8	12.2	10.2	17.7	20.5	12.2	3.0
D4	36.3	28.0	11.6	9.1	16.5	20.5	12.2	4.0
D5	56.0	36.2	15.9	13.2	22.0	23.3	12.2	4.0

Model

	D1	D2	D3	D4	D5
Hydraulic Flow Gallons per minute	12	20	25	35	50
Strainer Capacity, Gallons	0.8	1	2	2.5	3.5
Grease Collector Capacity, Gallons	1	1	1	1	3
Skimming Rate, Gallons per hour	0.5	0.5	1	1	3
Max Skimming Rate, with upgrade (Gallons per hour)	1.5	1.5	1.5	1.5	3

Casing Material 16 Gauge; 304 stainless steel; bright finish

Motor 25 Watt, 110V, 60 Hz
4.5 μ F capacitor

Heater 600 Watt, 110V,
D1, D2, D3, D4, D5 Thermal cut-out inc.

Controller Programmable
Logic Controller:
Backlit display
Inputs 110V AC
Outputs 110V AC
Battery back up

INSTALLATION

Part I: Undersink Example

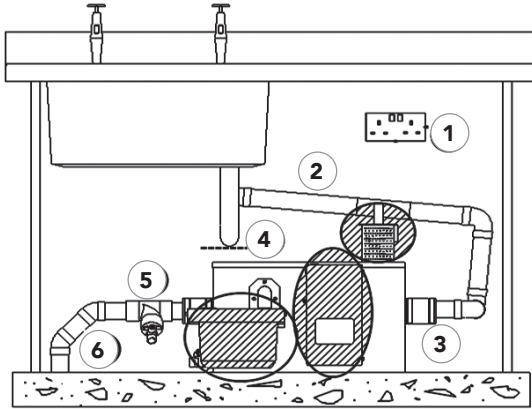

Appliances that can be directly connected include utensil sinks, pre-rinse sinks, combination ovens, wok cookers.



Daily access required, do not obstruct

- ① To be positioned within 2 metres (6.5 feet) of Grease Guardian unit
- ② Pipework between fixture and Grease Guardian to be minimally 1:40cm gravity fall ($\frac{1}{3}$ inch per foot)
- ③ Connect Grease Guardian inlet and outlet to piping using 2 x rubber clamp couplers as supplied
- ④ P trap to remain in place at sink. 40mm (1.5 inch) clearance to be observed between unit cover and P trap
- ⑤ Sample valve (where applicable) on outlet pipe, 45 degree spout position
- ⑥ Piping after Grease Guardian:
 - 50mm (2 inch) diameter minimal
 - 1:40 gravity fall to waste
 - no more than 3 metres (10 feet) distance
 - contain less than 3 x 90 degree bends

When under-appliance installation is not possible the Grease Guardian can be positioned next to the appliance, observing electrical and piping requirements above

Part 2: Pre Start Up Checks

1. Ensure unit is positioned on a level surface only and is plumbed in securely.
2. Ensure electrical outlet is waterproof and is fitted with or supported by a dedicated Residual Current Device or a properly grounded fault circuit breaker.

Points 3 and 4 below should normally be carried out by your market representative as part of unit commissioning:

3. Prior to mains switch-on ensure the unit is filled with water to the correct settlement level which occurs when the inflowing water stabilises at the base of the skimming wheel/drum.
4. Set the controller time of day and appropriate cycle programme in accordance with timer setting instructions detailed in this manual. Observe all maintenance requirements detailed in this manual.

HEALTH, SAFETY AND EFFICIENCY

- Never turn unit on before filling with water as instructed above.
- Disconnect unit from mains before accessing any electrical components
- Unit will lose efficiency if not Maintained.
- The unit is designed to trap and remove free floating grease oils and fats only
- The internal solids strainer provided protects the unit from coarse solid food waste build up. To help ensure the highest efficiency and reduce finer solid food-waste please install primary strainers in sinks and ensure food waste is scraped to bin before washing utensils
- Do not use Hazardous detergents to clean unit
- Do not install unit externally unless IP65 weather proof cover is used
- Do not connect a macerator or similar device upstream from the Grease Guardian
- Ensure unit is level and installed flat on the ground or frame where specified
- Remove blockages and grease build up from drains before installing the Grease Guardian
- If the supply cord is damaged it must be relaced by the manufacturer or authorised distributor
- Operation of the unit must be performed by trained personnel only

GREASE GUARDIAN CONTROLLER

Cycle Programming

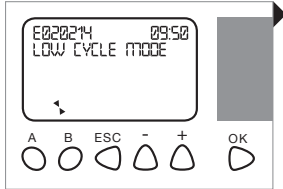

Initial Note: if no user adjustments are made a factory setting from 8am-12pm starts the unit on a LOW cycle daily. This is adequate for smaller applications including out of town delis, or small restaurants of less than 50 people. Otherwise refer to Appendix 1 at back of this manual for recommended settings for your application.

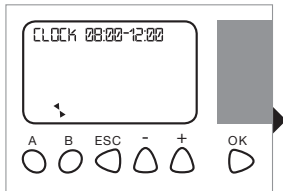

After machine switch-on, the home screen appears displaying the controller software version (in this case E for Europe and version date ddmmyy). The current time of day, and factory set cycle mode ARE also displayed.

To change a cycle first choose from one or more of the 4 hour programs **08:00-12:00**, **12:00-16:00**, **16:00-20:00**, and **20:00-00:00**, accessed by pressing the **OK** and **A** buttons together. Then advance through the time slots available by re-pressing **A**.

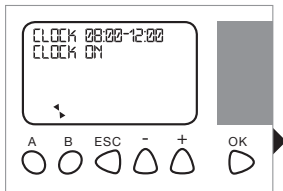

Any time-slot can be set to ON/OFF by pressing the **B** button. On completion press **ESC** to return to the home screen.

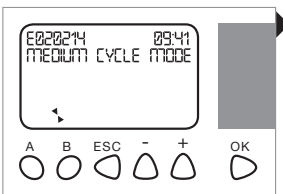

Finally in the home screen press and hold either the **+** or **-** keys for 1 second to fine tune the cycle duration. The display will indicate the adjustment made from 3 options

- **LOW Cycle Mode**
- **MEDIUM Cycle Mode**
- **HIGH Cycle Mode**

See Appendix 1 for suggested setting for your application

The time control displays the following information at various stages of a cycle.

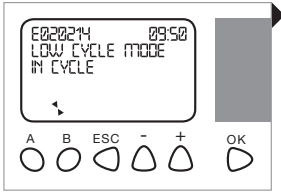

During a cycle both the heating element and the motor are activated to heat up and skim fats oils and greases. The main display flashes the message IN CYCLE. The full cycle sequence is shown in Appendix 2 for each user option chosen.

Controller Additional Features

Heater Off Mode

When wastewater entering the unit is sufficiently hot or if light oils are being intercepted the heater element may not be required. With this in mind there is an option to run cycles with the heating element deactivated. This feature will also provide savings on energy bills.

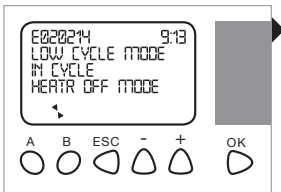

To disengage heating element:- from the Home Screen hold in button **B** for 10 or more seconds. The display appears as shown. In this mode the system runs any cycle with only the motor running at its normal pre-set operation.

See bottom of Appendix 2 for overview of timer sequence, for HEATR OFF MODE.

To re-engage the heater simply hold in the **B** button again for 10 seconds until the HEATR OFF MODE is cleared.

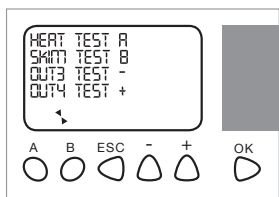

Test Mode

A test of electrical components can be conducted. Press **-** and **+** together to access this screen from the Home display. Next press any of the Test mode keys to activate the corresponding output:

- Press **A** key to activate Heater.
- Press **B** key to activate motor/skimmer.
- Press **-** key to activate Output 3
- Press **+** key to activate Output 4

Return to main menu by pressing **ESC**

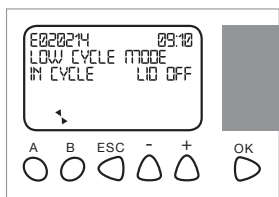

Lid Off Alert

If the main tank cover is removed from the unit at any time both the heater and motor will be stopped automatically for safety reasons. The display will flash a LID OFF alert until the lid is replaced. Power is restored to the heater and motor after the lid is replaced.

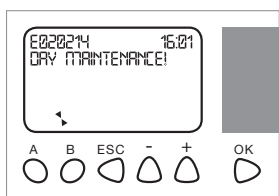

Daily Maintenance Reminder

Once every 24 hours this reminder message will flash on the controller display. The lid should be removed and solids basket checked and emptied. The grease container, internal wiper blade and grease channel should also be checked at this time. On replacement of lid the maintenance reminder is re-set for another 24 hours.

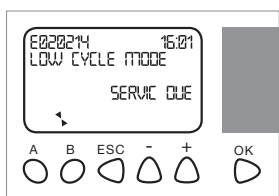

Scheduled Service Reminder

The Grease Guardian unit requires periodic service inspection and pump out by qualified personnel. To assist, the controller is pre-set to display a service due reminder as shown on the due date. Please contact your Service Provider when this display appears. The reminder will normally flash at least once every 90 days in line with service and pump out requirements for this product.

Building Management System feature

Please note that the output switch No. 4 of this controller is available for connection to BMS system. The rating for this output is 24 to 250VAC, 8 AMPS max. The signal to BMS from this output is factory programmed to indicate power ON during normal operation of the controller.

If either a/ there is a power failure or b/ if the main tank lid is misplaced from the system for more than 10 minutes, then the continuous signal to BMS is interrupted, indicating that either of these faults has occurred.

Controller Additional Settings: Time Reset and 7 Day Setting

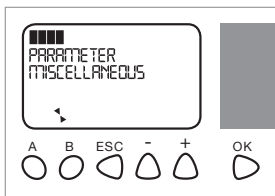

Time of day Set

From the main display access the above display by pressing **OK** and **ESC** together. Choose MISCELLANEOUS using **-** or **+** keys then press **OK**

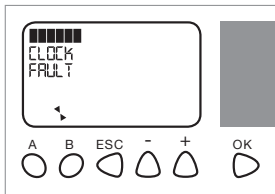

In the follow on display use the **+** and **-** keys to move the flashing bar to select CLOCK. Press **OK** to confirm.

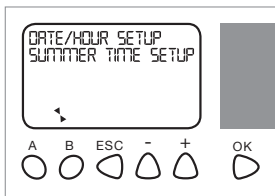

Next, use the **+** and **-** keys to select DATE/HOUR SETUP, and press **OK**

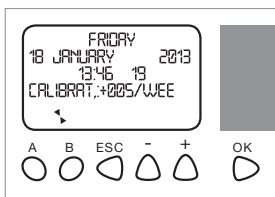

Use the **+** and **-** keys to move the flashing bar to select current hour and minutes blocks. Enter and change these digits by pressing **OK**, then use **+** and **-** keys to increase/decrease values. Press **OK** to confirm current value. Press **ESC** to save and return to home display.

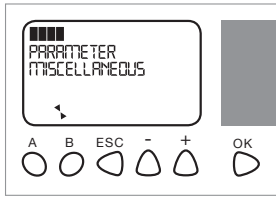

7 day ON/OFF Control

From the main display access the above display by pressing **OK** and **ESC** together. Choose PARAMETER using **-** or **+** keys then press **OK**

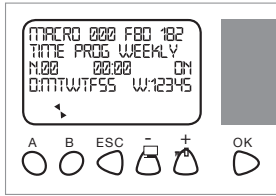

The display to the left will show. Next using only the **-** key move the cursor to the D:MTWTFSS block (days of week). To access particular day value press **OK**. Then press **-** to cancel any day. Pressing **OK** confirms cancellation and moves the cursor to the next day. On reaching final Day value, S, press **OK** to confirm all.

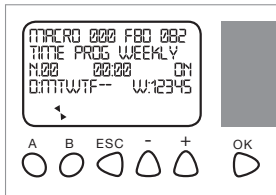

Example: Controller set to OFF at weekends; the display is configured as shown left. Press **ESC** to exit to home display.

ENGINEER SETTINGS

COMMISSIONING AND SERVICE

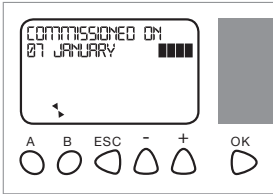

“Commissioned on” date Logger

A basic reference display is used to log the commissioned date for the unit. The display can be checked or changed at any time by accessing the menu as shown.

To Check:

From the main display press **OK** and the **B** button together. The Day, Month and Year values will appear. Press **ESC** to return to the main display after checking.

To Change:

In this display select the day, month or year by pressing either **+** or **-** keys to move the flashing bar through these fields. To lock onto a specific field, press **OK**. The bar icon is dimmed out. Next use **+** and **-** keys to increase or decrease the date value. When the value is set press **OK** to store, and then move to the next field and repeat. Finally press **ESC** to return to the main display.

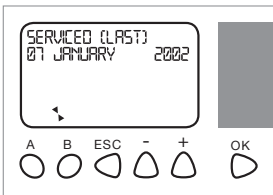

“Last Service” date Logger

A basic reference display is used to log the last service date for the unit. The display can be checked or changed at any time by accessing the menu as shown.

To Check:

From the main display press **OK** and the **B** button together. Then Press **B** again to reach the Service menu. The Last service day, month and year will appear. Press **ESC** to return to the main display after checking.

To Change:

In the serviced (last)" display select the day, month or year by pressing either **+** or **-** keys to move the flashing bar through these fields. To lock onto a specific field, press **OK**. The bar icon is dimmed out. Next use **+** and **-** keys to increase or decrease the date value. When the value is set press **OK** to store, and then move to the next field and repeat. Finally press **ESC** to return to the main display.

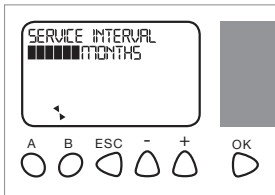

Service Reminder Interval Setting

This feature sets the interval for the flashing service reminder display. The interval option can be set at a frequency of 0-12 months. The factory default is set at 3 months. No reminder: Setting the interval to "0" overrides the function and there is no reminder.

To Check:

From the main display press **OK** and the **B** button together. Then Press **B** twice again to reach the Service menu. The current interval in month will appear. Press **ESC** to return to the main display after checking.

To Change:

In the SERVICE INTERVAL display select the month by pressing **OK**. The bar icon is dimmed out. Next use **+** and **-** keys to increase or decrease the month value. When the value is set press **OK** to store. Finally press **ESC** to return to the main display.

Note: To Reset Service Reminder Alert.

To cancel the flashing Service Reminder message after a service is completed: In the Service Interval Menu press **A** for 5 seconds. The message is cancelled and will reset for the next interval.

GENERAL HOUSEKEEPING

Daily

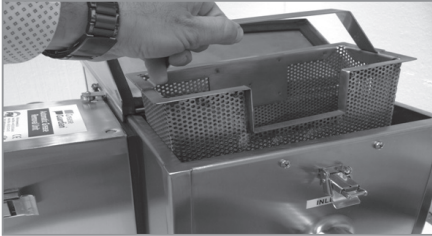

Remove lid and empty strainer basket into bin. Replace basket and secure lid.



Empty collection container into barrel. This can then be taken away by a local rendering company for recycling.



Open lid and remove, clean and replace detachable wiper blades.

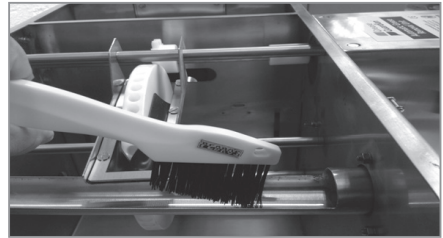

Use a brush to clear grease deposits from the internal channel and external pipe bend above the grease container.

Weekly



Fill sinks with clean water and empty to flush through unit. This keeps freshwater in tank. Always ensure water level is reaching wheels.

TRI-MONTHLY MAINTENANCE

External Service Partner

ATTENTION!

In addition to the daily and weekly housekeeping, all Grease Guardian units must receive one service inspection **every 3 months to be completed by an approved FM Environmental service provider only**. Failure to implement this service could result in impairment of unit performance or system failure.

The service will consist minimally of the following steps:

Unit pump out:

To remove both settled and suspended solids. A thorough inspection and cleaning of the heating element will also be carried out each time



Inspection of all wear and tear parts

Including Wiper rubber, flow restrictor rubber and lid seal gasket. Replacement of parts if necessary

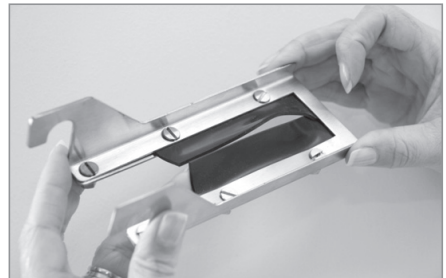

Electrical checks

Including controller, heater and motor checks. Optimisation of components will be made if necessary.



TROUBLESHOOTING

PROBLEM: Not skimming

Is the power on?

Check the power is on and the time control is set correctly. Check mains connection. If power is being supplied and there is still no display check fuses or contact your supplier.

Are removable parts cleaned?

Remove the lid and clean away any build-up that may be present in the wiper blades, collection channel or outlet hose. Ensure that the wiper blades are clipped properly in place on the skimmer wheels. Replace wiper blades when worn.

Check the skimming and heating cycles

The Grease Guardian heating and skimming cycles should be set to remove grease that is trapped. Make sure the cycles have been correctly set as per instructions.

(Heater) the tank should heat (25 mins approx). If the tank does not heat the heater may need inspecting. Contact your local service engineer to check.

(Wheel) after heating for 25 minutes, check to make sure that the noise of the skimmer wheel turning is heard. If the motor can be heard but the wheels are not turning then check the axles and drive couplings that link the motor to the wheel. If the skimmer motor does not come "on", the motor must be checked by qualified engineers for possible replacement.

Make sure wiper blade assembly is secure

Position wiper blade assembly over the wheel and secure to shaft. If rubber blades brittle over time, replace.

Check the magnet & switch

A safety magnetic switch is found on the control panel whilst the magnet itself is attached to the main lid of the Grease Guardian. Make sure that the lid magnet has not been damaged. Ensure the distance between magnet and control panel is not more than 10mm for proper contact.

Check the lid

The unit will not operate when the lid is removed or incorrectly positioned.

PROBLEM: Excessive water is observed in the grease collection container

Check Timer Cycle Settings

Check the timer cycle settings for excessive "ON" time. Decrease the cycle length as advised in the timer settings of this manual. The unit should not run extensively after the grease and oils have been skimmed.

Check water flow

Surge water may overspill into the container. Ensure that the water flow to the unit does not exceed the rated flow and that there are no drain line blockages downstream from the unit.

PROBLEM: Excess steam comes out of unit

Siphoning

This results in a reduced level in the unit caused by the effect of "siphoning". This occurs in particular installations where the downstream piping of the unit is not properly installed. If this occurs, turn off the unit immediately and consult the plumber or the distributor for more advice.

PROBLEM: Water overflows from the unit

Has the strainer basket been maintained?

If water overflows from the inlet chamber the basket may need emptying. Remove, clean and re-install. Ensure that the water flow to the unit does not exceed the rated flow and that there are no drain line blockages downstream from the unit.

Does the inlet gasket need replacing?

General overflowing can also result from a worn inlet gasket or a blocked outlet pipe. Replace gasket and clean all possible blockages downstream of the unit.

Has sediment been allowed to build up over time?

Over time, sludge could have built up at the bottom of the unit and is blocking the path of the flow underneath the outlet baffle. Ensure the unit is pumped out as per maintenance instructions.

PROBLEM: Odour Reported

Has maintenance been carried out?

Ensure housekeeping is carried out as detailed in this manual
Ensure the unit is pumped out as per maintenance instructions.

Standard Warranty

FM Environmental warrants, to the original user, that those products supplied by it and used in the service and in the manner for which they are intended shall be free from defects in materials and workmanship for a period of 1 YEAR.

- a) The warranty period commences from the date goods are dispatched to original user or from the date unit is commissioned provided that commissioning form or other receipt is supplied with claim and that commissioning is carried out within three months of equipment being dispatched.
- b) All warranty claims must be processed through the Dealer from whom the equipment was purchased. The Dealer will co-operate with the purchaser throughout the warranty claims procedure and will arrange any necessary repairs using genuine Grease Guardian parts.
- c) If the original Dealer is no longer able to fulfill their obligations please contact FM Environmental Limited with full details of the claim and proof of purchase or commissioning so that this may be processed without delay.
- d) Any warranty claim can only relate to a specific part that is proven to be at fault and for which a replacement will be supplied but cannot be extended to constitute a claim against the complete appliance.
- e) FM Environmental Ltd will supply the Dealer with any warranty parts required subject to the claim being validated after return of the faulty items.
- f) All replacement parts have a 60 day replacement warranty. Clean defective parts shall be returned, within the warranty period, with proof of purchase, to FM Environmental, transportation charges prepaid, for warranty evaluation. At FM Environmental option, based on the determination of the warranty evaluation, FM Environmental may repair or supply a replacement part from its factory. Any and all items which may be returned shall include the serial number of the unit from which the item was removed, and a return goods authorization number issued by FM Environmental.
- g) This warranty is void if the product has been damaged by its customer prior to acceptance or as a result of unreasonable use, neglect, flooding, alteration, improper installation, improper tri-monthly (4 times yearly) service, maintenance neglect, improper electrical service, installation and/or operation without timer controls, or other causes not arising out of defects in material or workmanship. Equipment must be installed according to manufacturer's guidelines. This warranty is void if equipment is used in excess of rated flow. FM Environmental products are intended to remove only free floating oils and grease. FM Environmental products do not remove emulsified fats and oils. FM Environmental shall not be responsible for damage to equipment which results from vault flooding, sewer line back-up, pumping or lift station failure, ambient water flow or other sources of water damage. This warranty is void if the serial number on the product has been altered or defaced. FM Environmental will not replace electrical parts which have been installed in under-ground vaults. This warranty is void should use, installation and application be contrary to a written agreement between FM Environmental and the user,
- h) FM Environmental does not make any other representations or warranties, express or implied, including, but not limited to, any implied warranty or merchantability and any implied warranty of fitness or performance for a particular purpose.
- i) The sole and exclusive remedy with respect to the above limited warranty or with respect to any other claim relating to defects or any other condition or use of the product supplied by FM Environmental, however caused, and whether such claim is based upon warranty, contract, negligence, strict liability or any other theory, is LIMITED to the repair or replacement of the part or product, excluding labour or any other cost to remove or install said part or product or, at FM Environmental option, to repayment of the purchase price. Notice of any such claim must be given in writing to FM Environmental within 15 months after the fault installation and / or use of the product
- j) In no event shall FM Environmental be liable for special, direct, indirect, incidental, personal, property or consequential damages, including but not limited to, loss of use or profits or to interruption of business activity. FM Environmental neither assumes nor authorizes any representative or any other person to assume any liability in connection with the sale of its products. FM Environmental makes no warranties, express or implied, with respect to parts, accessories, components or other goods not in FM Environmental scope of supply. Alteration and/or substitution of FM Environmental parts, assemblies, accessories including electrical and/or mechanical components voids FM Environmental warranty.

10 YEAR ANTI - PERFORATION WARRANTY ON GREASE GUARDIAN STAINLESS STEEL TANK

FM Environmental warrants, to the original user, that The Grease Guardian main tank (location in which grease is trapped) supplied and used in the service and in the manner for which it is intended shall be free from defects in materials and workmanship for a period of 10 YEARS. This Warranty is void should the product be damaged by its customer prior to acceptance or as a result of unreasonable use neglect, alteration, improper installation, improper service, maintenance neglect, installation or other causes not arising out of defects in material or workmanship. The warranty will also be void should the stainless steel tank be found to be in direct contact with copper, brass, or corrosive chemicals (acidic or alkaline), saline water (PPM > 1000) for excessive periods

Appendix 1: D1 to D4 wiring diagram (230V)

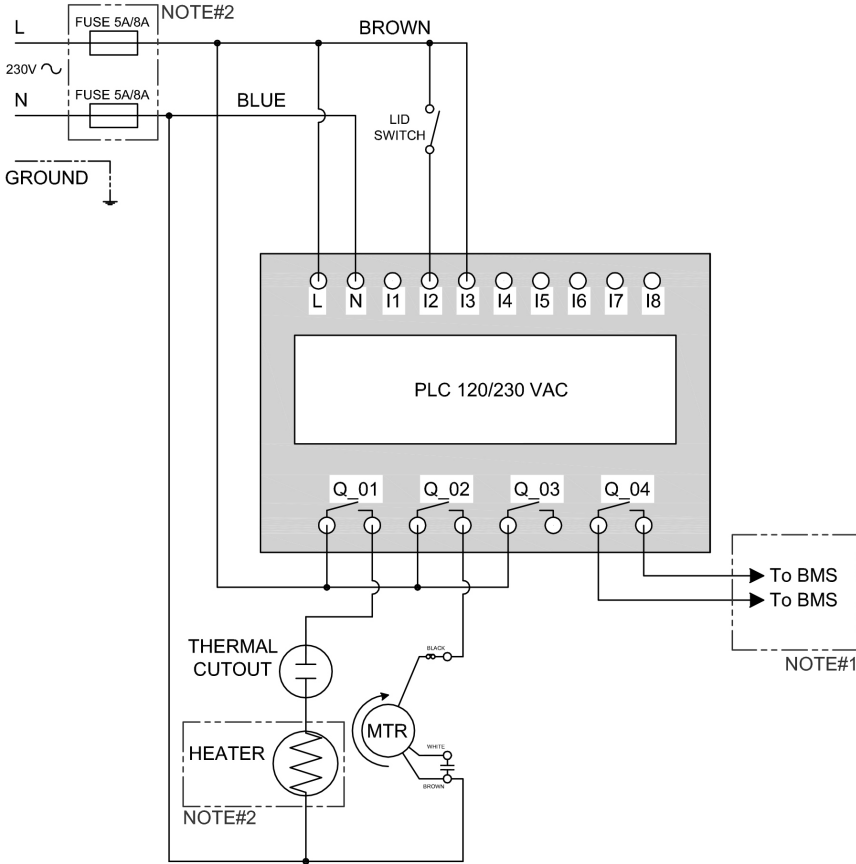

NOTE #1: OPTIONAL - If connecting Output 4 (normally closed contact) to the BMS (Building Management System) ensure that the maximum breaking voltage (5-30VDC, 24-250VAC) and maximum breaking current (8A) are not exceeded

NOTE #2: For D1 and D2 models, fuse sizes are 5A and heater size is 600W. For D3 and D4 models, fuse size is 8A and heater size is 1000W.

Appendix 2: D1-D4 wiring diagram (110V)

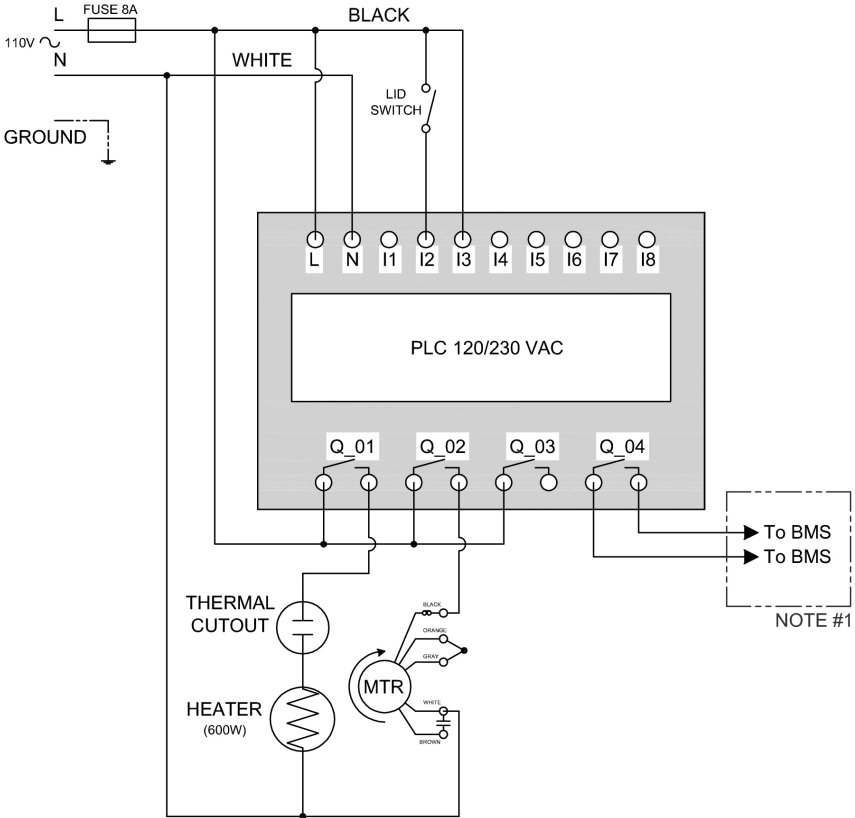

NOTE #1: OPTIONAL - If connecting Output 4 (normally closed contact) to the BMS (Building Management System) ensure that the maximum breaking voltage (5-30VDC, 24-250VAC) and maximum breaking current (8A) are not exceeded

Appendix 3: D5 wiring diagram

D5 WIRING DIAGRAM - 230V

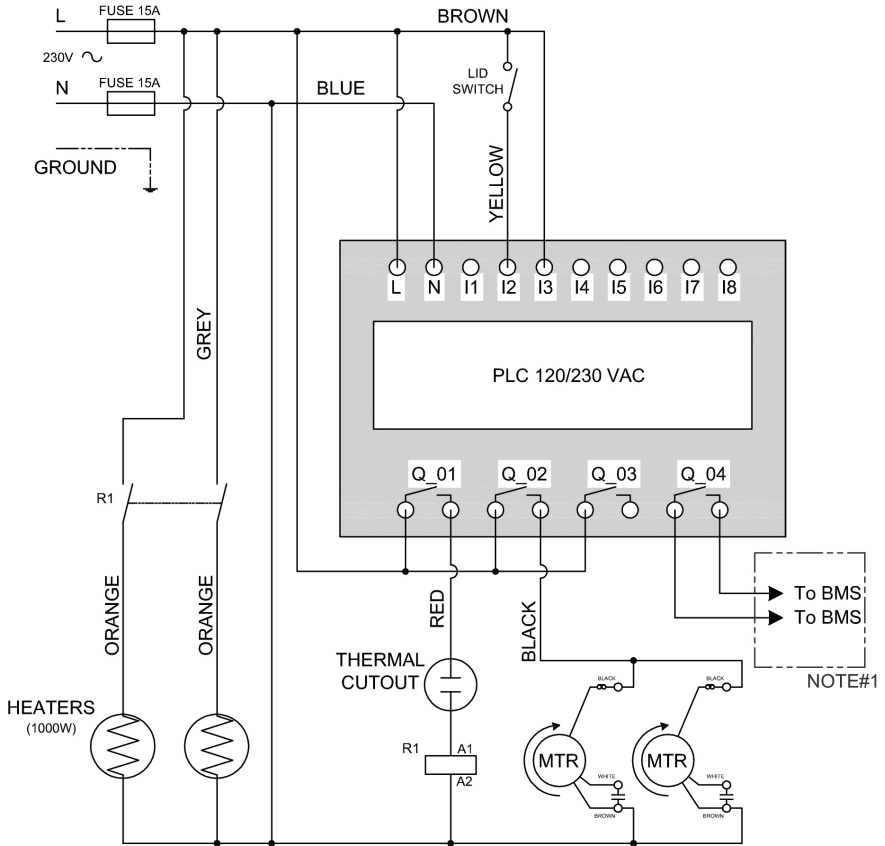

NOTE #1: OPTIONAL - If connecting Output 4 (normally closed contact) to the BMS (Building Management System) ensure that the maximum breaking voltage (5-30VDC, 24-250VAC) and maximum breaking current (8A) are not exceeded

Notes



Grease Guardian®

Frontline Engineering



HEAD OFFICE
FM Environmental Ltd

Greenbank Industrial Estate
Newry, BT34 2QX, N, Ireland

Telephone: +44 [0] 28 302 66616

From ROI Call: 048 302 66616

Fax: +44 [0] 28 302 63233

Email: gg@fmenvironmental.com

www.fmenvironmental.com
www.greaseguardian.com

MALTA OFFICE
FM Environmental [Malta] Ltd

Water Technology House
A15B Industrial Estate Marsa, Malta

Telephone: +356 2122 6172/3

Fax: +356 2122 6171

Email: fmmalta@fmenvironmental.com

UNITED STATES OFFICE
Grease Guardian LLC

96 Onondaga Street
Yonkers NY 10704

Telephone: +001 914 375 0902

Mobile: +001 914 316 5671

Email: des@greaseguardian.com

www.greaseguardianusa.com

