

ITEM NO.	PART NUMBER	QTY.
1	SPE_#2163G15_1500L Grease Separator.STEP	1
2	Ø110 Inlet Baffle_HDPE DN100_Default_As Machined_.STEP	1
3	Ø110 Outlet Baffle_HDPE DN100_Default_As Machined 1500.STEP	1
4	Ø110 x120mm Vent Spiggot_HDPE DN100.STEP	2
5	ACO_Grease Separator_SPE Adaptor Collar.STEP	1

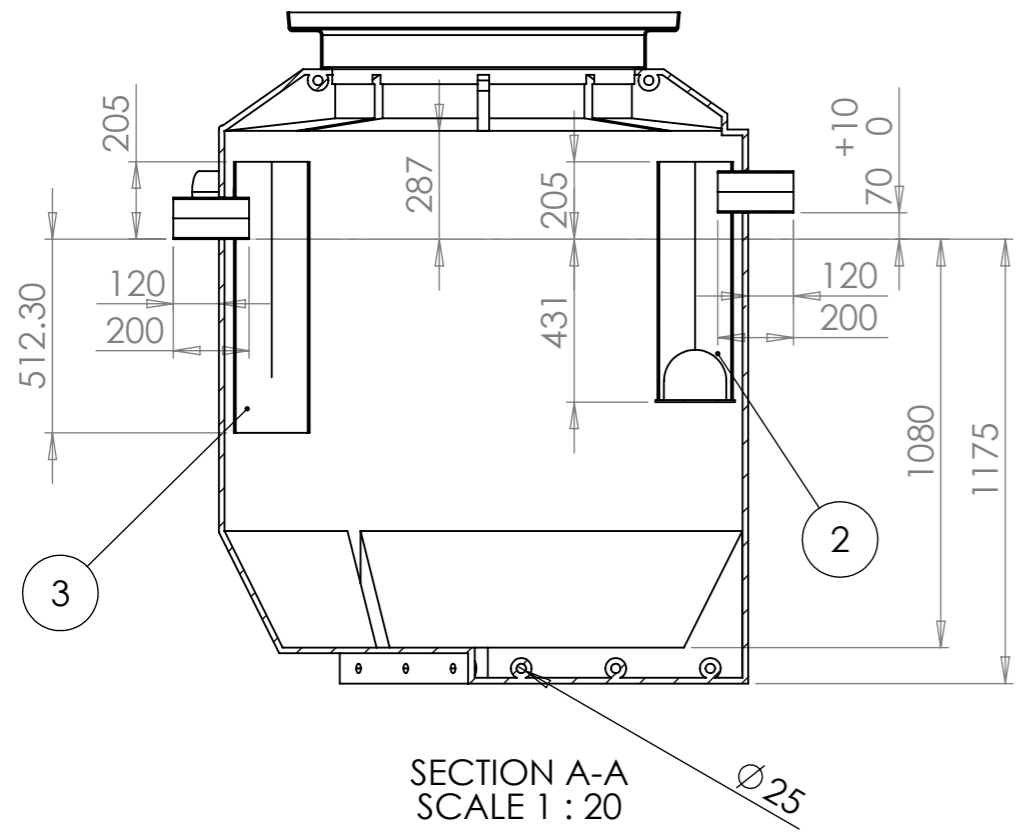
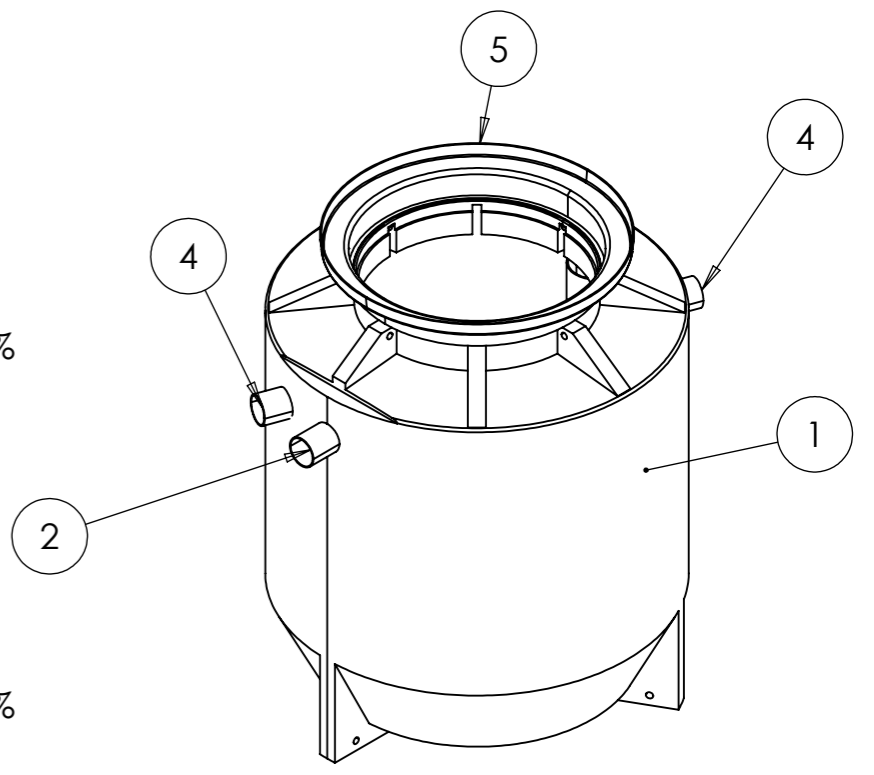
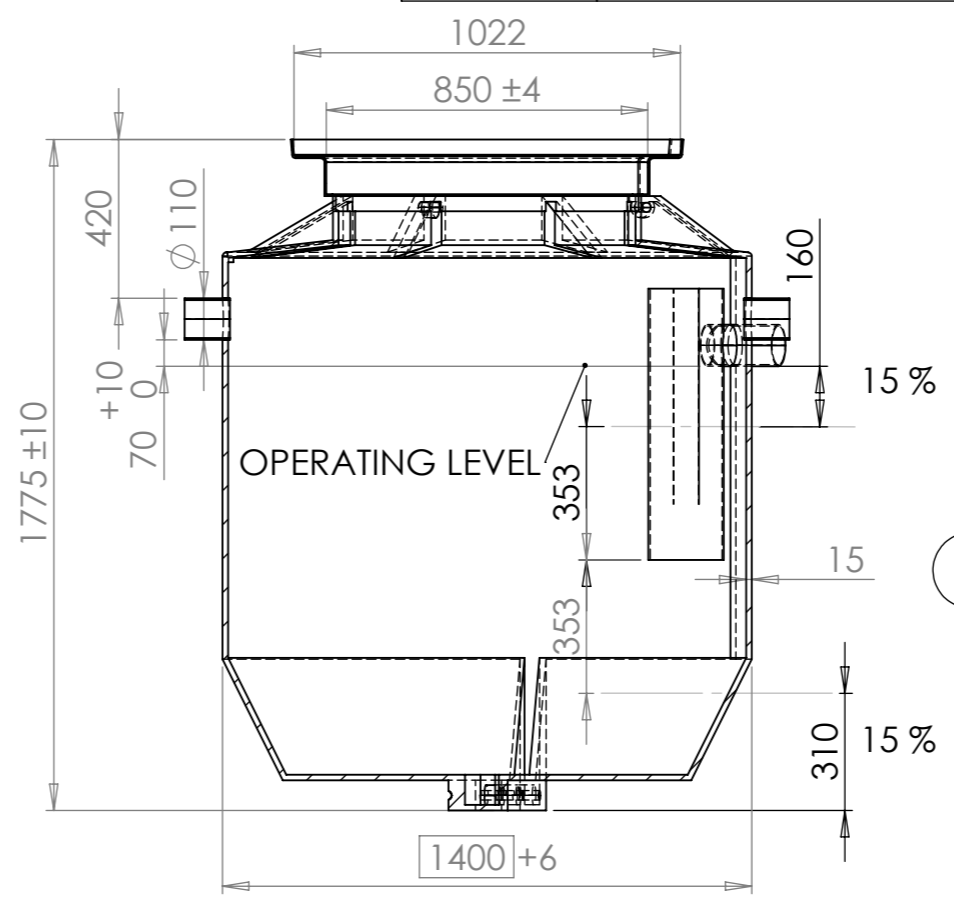
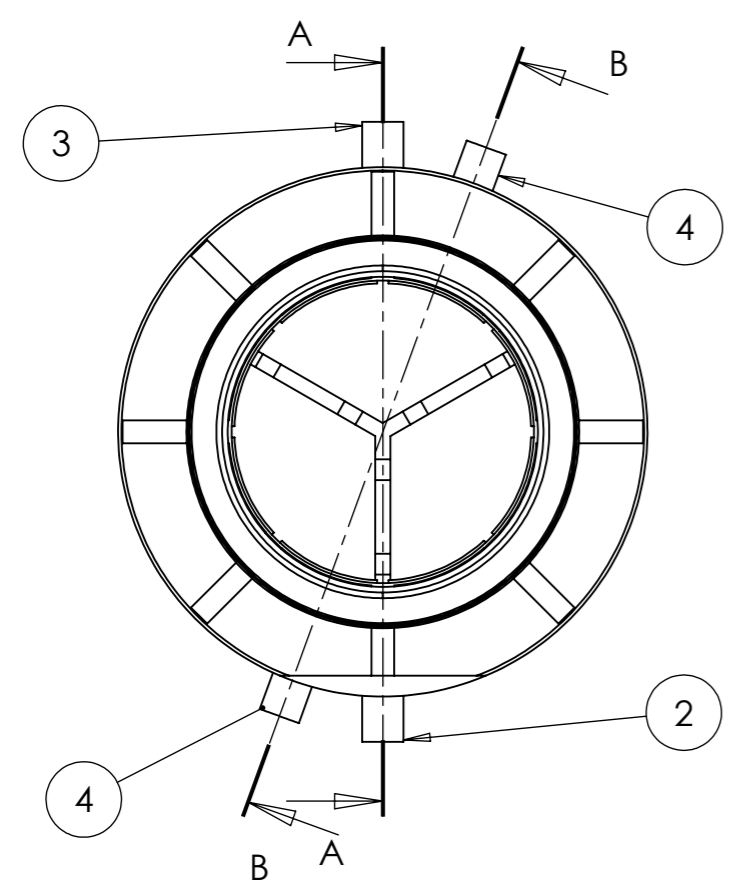

- Note:**
- Following information must be clearly evident on conformance plate.
 - Standard : AS 5215
 - Manufacturer name : ACO
 - Part No : 143268
 - Volume : 1500L
 - Maximum grease storage depth : 160 mm
 - Maximum solids storage depth : 310 mm
 - Month and year of manufacture : MM/YY
 - Conformance plate to be clearly visible after installation.
 - Following markings to be clearly marked on the body of grease arrestor.
 - Model number or product identifier : LIPUMAX PPE - 1500L
 - Dry weight : 151 kg
 - Lifting Points
 - Inlet
 - Outlet
 - Vent
 - Both vents at same height.
 - For Conformance plate see drawing Y043.

Rev	Description	By	Date
A	Outlet Baffle length changed	SN	31.10.23

Revisions

ACO Pty Ltd
ACN 050 102 942
ABN 65 050 102 942
134 Old Bathurst Road,
Emu Plains NSW 2152
Tel: 02 4747 4000
Fax: 02 4747 4040
Website: www.acoaus.com.au

Information contained in this drawing is copyright property of ACO. Any reproduction in part or whole without written permission of ACO is prohibited.

DO NOT SCALE

Drawn by: SHEHRYAR Date: 05.01.23 Range: LIPUMAX

Material: LLDPE Finish: - Weight : kg 151

Job title: LIPUMAX 1500L

Page title: DETAILS

CUSTOMER APPROVED		MANUFACTURING APPROVED	
Name:	Date:	Name:	Date:
-	-	-	-

Scale: 1:20 Units: mm Part or order No: 143268 Drawing No: Y038 Rev: A Sheet: 1 OF 1

Y038 SHEET SIZE: A3

TOLERANCE EXCEPT WHERE OTHERWISE STATED : ±1%