

| ITEM NO. | PART NUMBER  | QTY. |
|----------|--|------|
| 1        | SPE_#2164G3_3000L_Grease Separator.STEP  | 1    |
| 2        | Ø110 Inlet Baffle_HDPE DN100_0170.22.93_inlet_2_4_Default_As Machined_.STEP      | 1    |
| 3        | Ø110 Outlet Baffle_HDPE DN100_0170.22.94_outlet_2_4_Default_As Machined3000.STEP | 1    |
| 4        | Ø110 x120mm Vent Spiggot_HDPE DN100.STEP   | 2    |
| 5        | ACO_Grease Separator_SPE Adaptor Collar.STEP                                     | 1    |

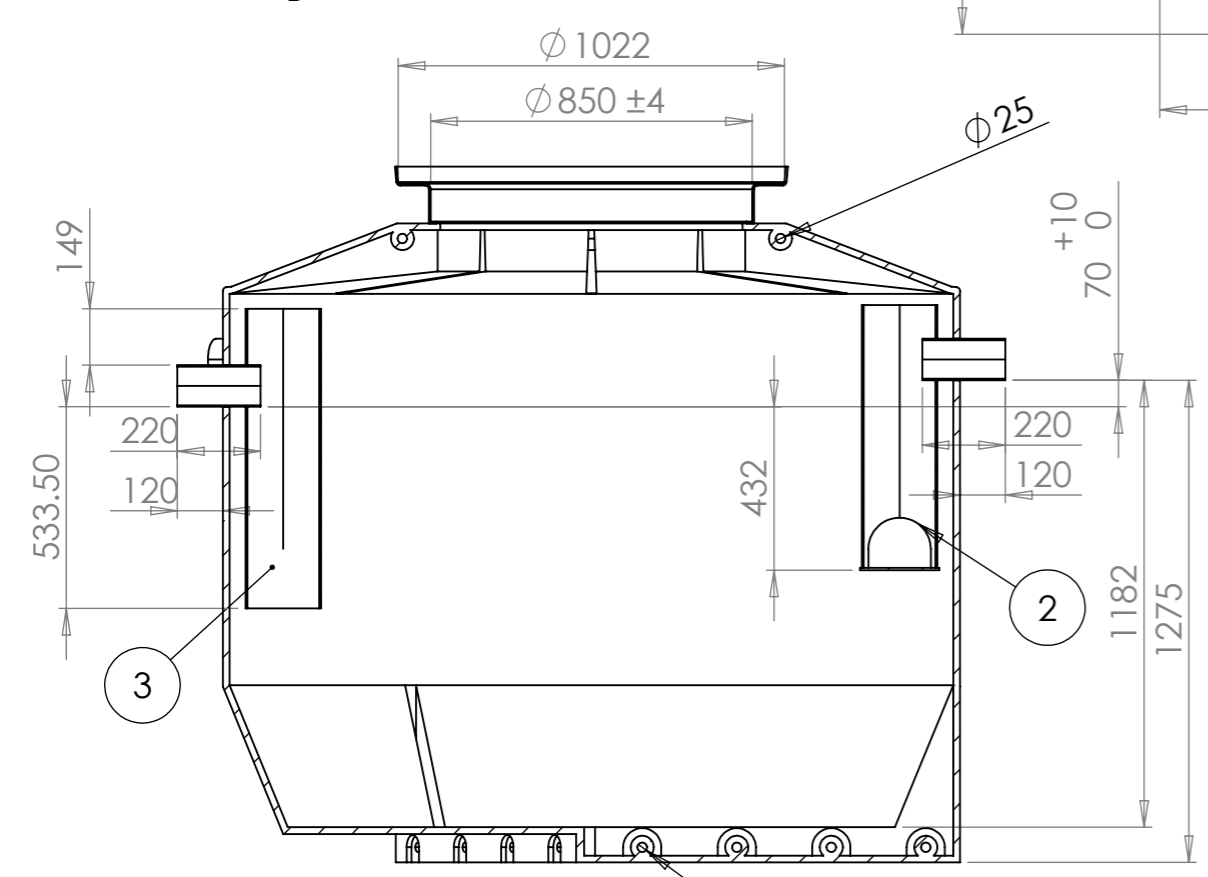
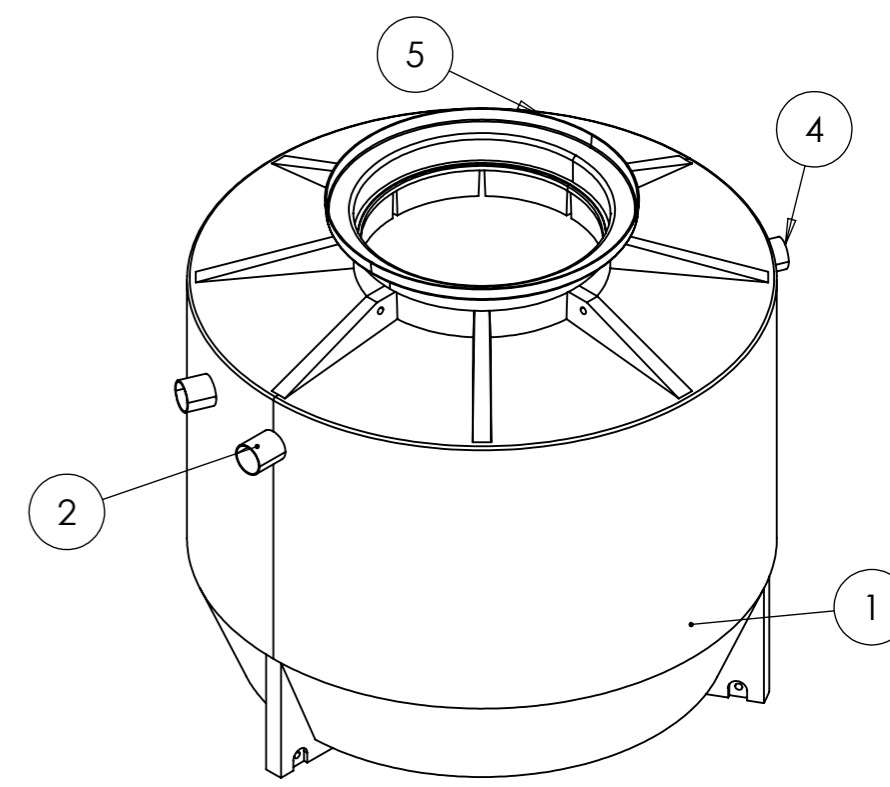
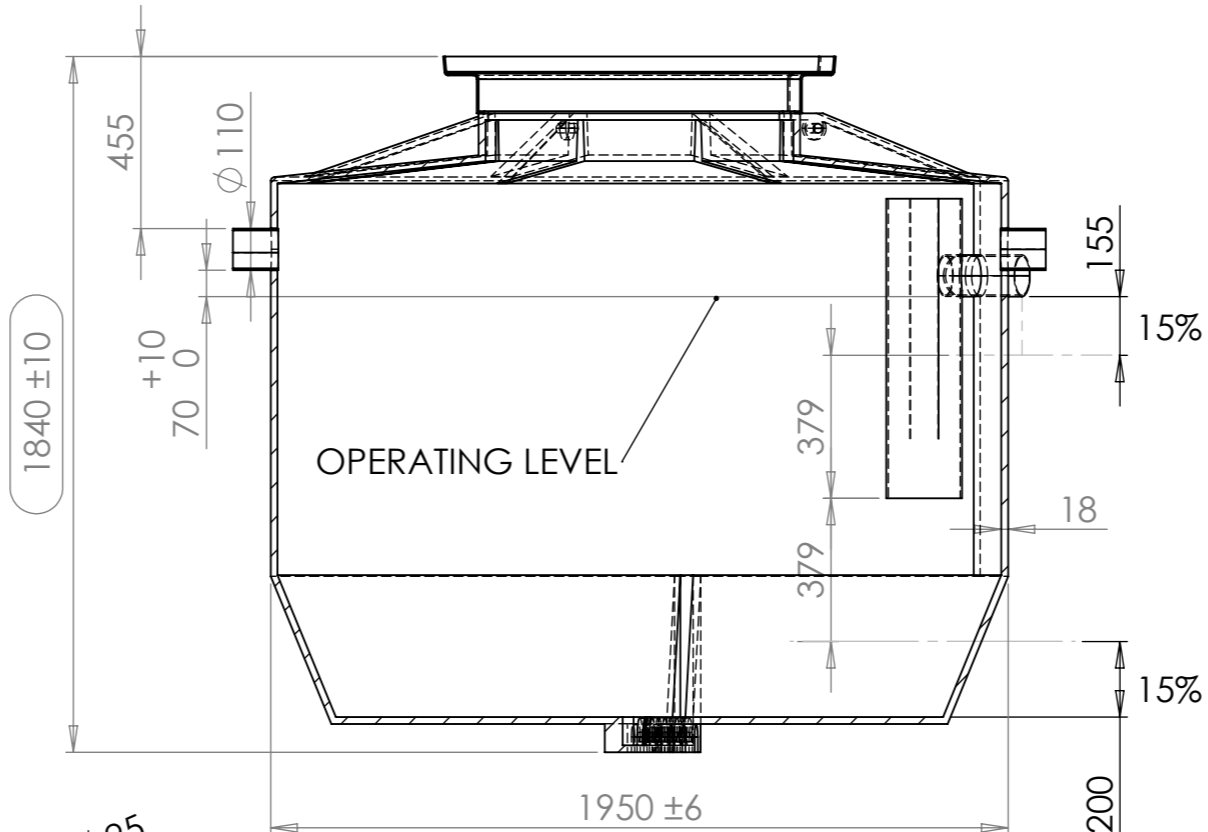
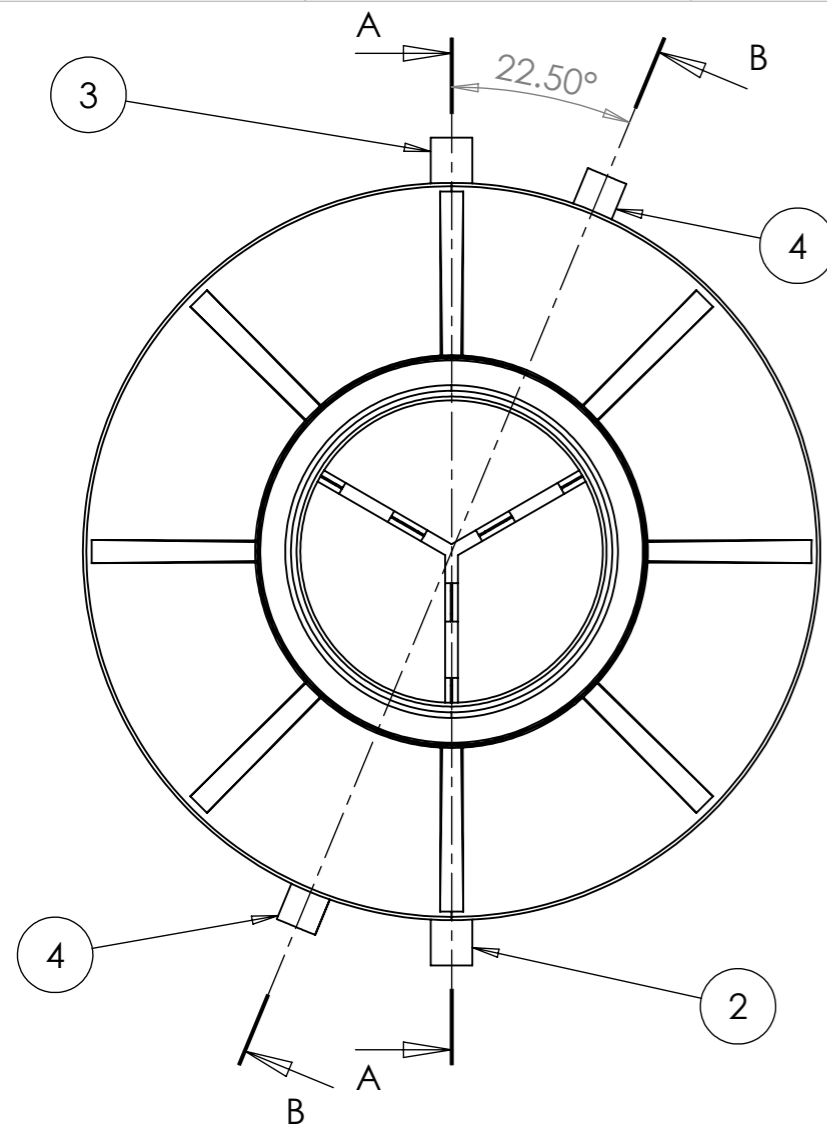

- Note:**
- Following information must be clearly evident on conformance plate.
    - Standard : AS 5215
    - Manufacturer name : ACO
    - Part No : 143270
    - Volume : 3000L
    - Maximum grease storage depth : 155 mm
    - Maximum solids storage depth : 200 mm
    - Month and year of manufacture : MM/YY
  - Conformance plate to be clearly visible after installation.
  - Following markings to be clearly marked on the body of grease arrestor.
    - Model number or product identifier : LIPUMAX PPE - 3000L
    - Dry weight : 287 kg
    - Lifting Points
    - Inlet
    - Outlet
    - Vent
  - Both vents at same height.
  - For Conformance plate see drawing Y043.

TOLERANCE EXCEPT WHERE OTHERWISE STATED : ±1%

| Rev | Description                  | By | Date     |
|-----|------------------------------|----|----------|
| A   | Outlet Baffle length changed | SN | 31.10.23 |

**Revisions**

**ACO Pty Ltd**  
ACN 050 102 942  
ABN 65 050 102 942  
134 Old Bathurst Road,  
Emu Plains NSW 2152  
Tel: 02 4747 4000  
Fax: 02 4747 4040  
Website: www.acoaus.com.au

Information contained in this drawing is copyright property of ACO. Any reproduction in part or whole without written permission of ACO is prohibited.

**DO NOT SCALE**

Drawn by: SHEHRYAR Date: 05.01.23 Range: LIPUMAX  
Material: LLDPE Finish: - Weight : kg 287  
Job title: LIPUMAX PPE 3000L

Page title: DETAILS

| CUSTOMER APPROVED |       | MANUFACTURING APPROVED |       |
|-------------------|-------|------------------------|-------|
| Name:             | Date: | Name:                  | Date: |
| -                 | -     | -                      | -     |

Scale: 1:20 Units: mm Part or order No: 143270 Drawing No: Y040 Rev: A Sheet: 1 OF 1

Y040 SHEET SIZE: A3