

HALGAN™ MGTA2000-WA ABOVE GROUND DETAIL

1. General

- 1.1. Tank constructed from Polyethylene.
- 1.2. Is to be installed in a location that will not cause a nuisance, obstruct fire access, cannot be vandalised or be damaged by vehicles.
- 1.3. Must have ease of access to pumpout point for maintenance.
- 1.4. Non standard installations require Halgan approval.

2. Installation above ground

- 2.1. The Halgan Tanks to be supported on a 100mm thick concrete pad.
- 2.2. Any maintenance platform must be installed in accordance with Australian Standard 1657-1992 allowing safe access while inspecting and maintaining.
- 2.3. All pipes connecting shall be fully supported; there shall be no stress on the tank connections.
- 2.4. All stormwater must be diverted away to prevent undermining of foundation.

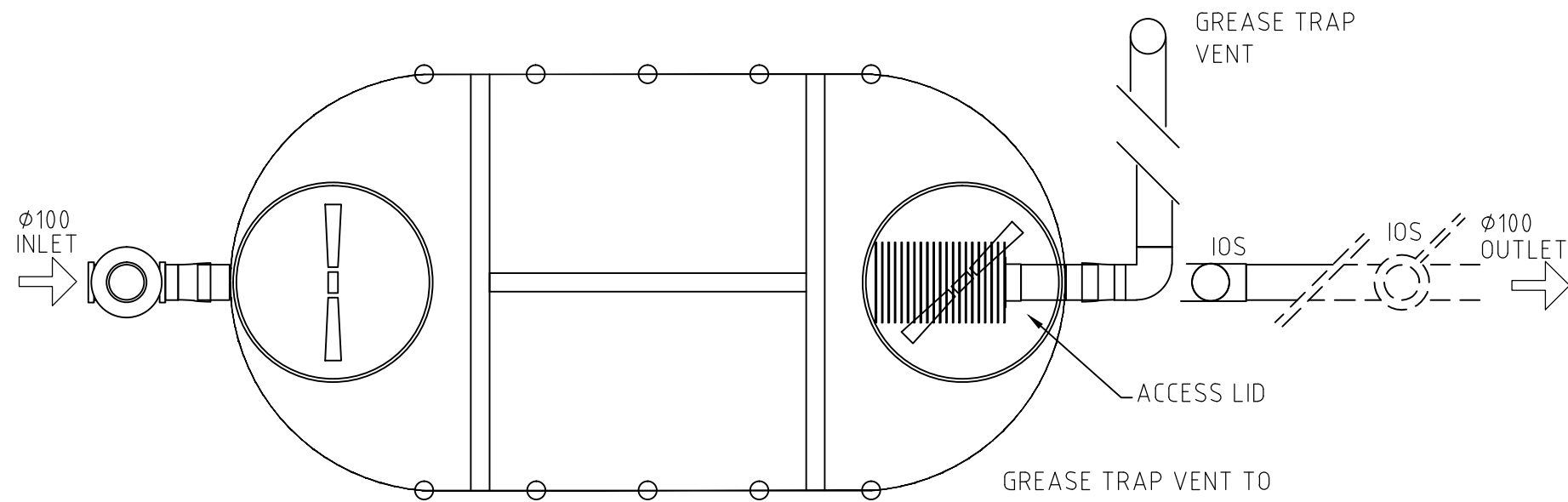

PLAN VIEW

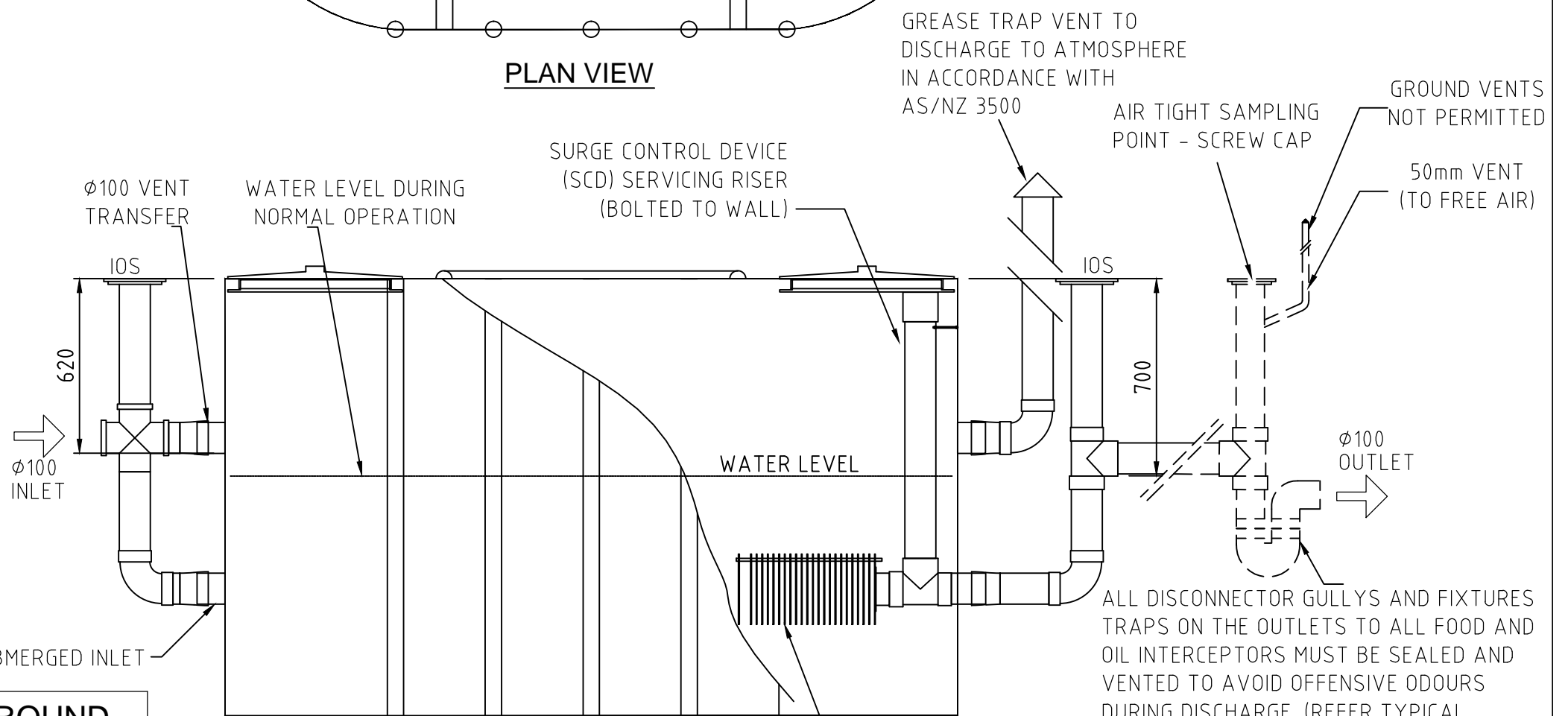

ELEVATION

HALGAN MGTA2000-WA ABOVE GROUND					
MODEL	HEIGHT	WIDTH	LENGTH	VOLUME	WEIGHT
MGTA2000-WA	1550mm	1350mm	2800mm	2000 L	215 KG

REV	DATE	DESCRIPTION	BY	CHKD	APP
A-1	11-01-2017	UPDATED DESIGN	LB	JB	KH
A	02-06-2014	DETAIL DESIGN	NM	SM	KH

THIS DRAWING AND THE INFORMATION CONTAINED HEREON ARE THE PROPERTY OF HALGAN PTY LTD AND MUST NOT BE COPIED, REPRODUCED OR USED WITHOUT THE WRITTEN PERMISSION OF HALGAN PTY LTD.

DO NOT SCALE IF IN DOUBT ASK



halgan pty ltd
halgan.com.au

Freecall 1800 626 753
PO Box 255
22 Ethel Avenue
Brookvale NSW 2100
admin@halgan.com.au
www.halgan.com.au



HALGAN MGTA2000-WA
ABOVE GROUND DETAIL

DRAWN	DATE	SCALE	REV.
LB	11.01.2017	-	A3
CHECKED			
JB			
DWG NO.			
MGTA2000-WA			A-1