

SECTION C-C

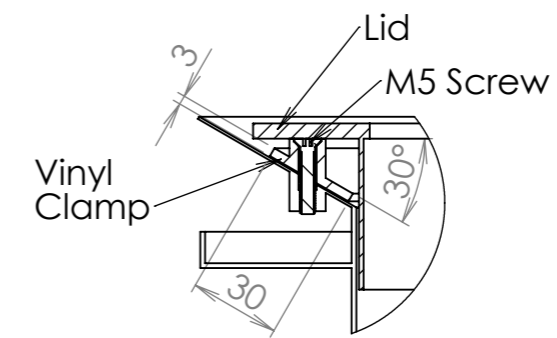

DETAIL D
SCALE 2 : 5

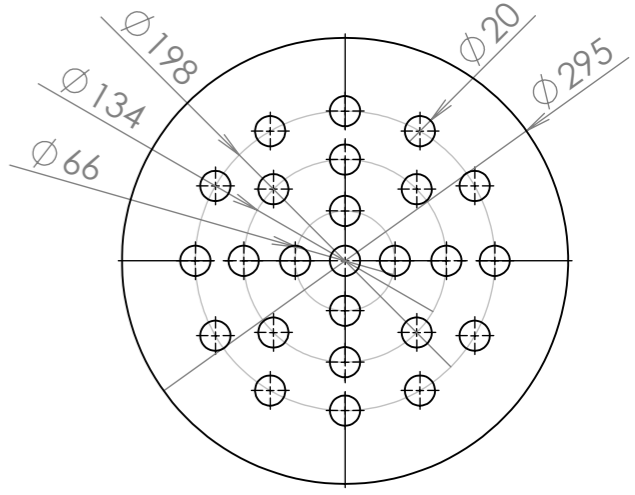
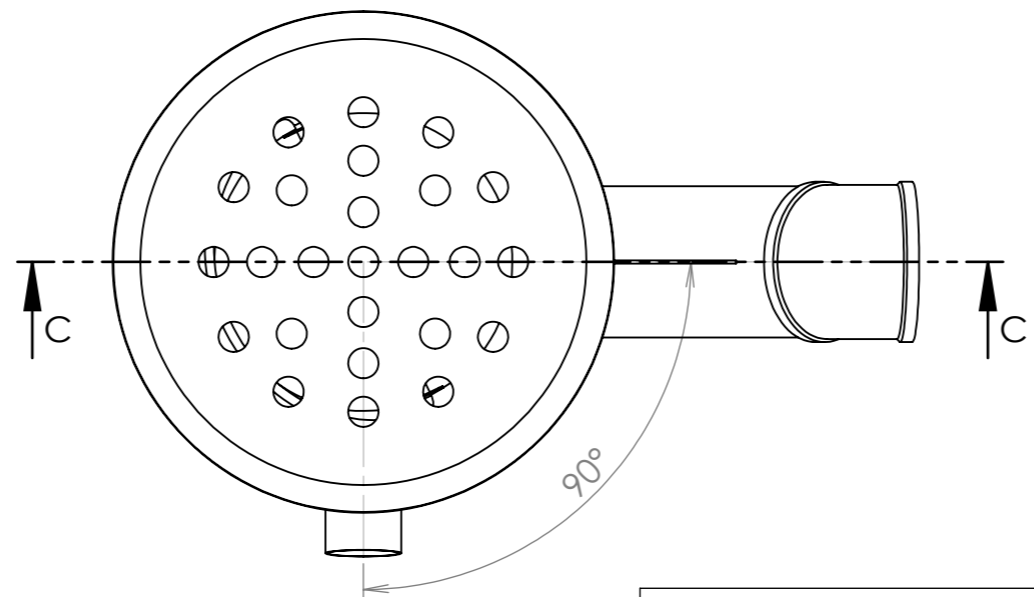
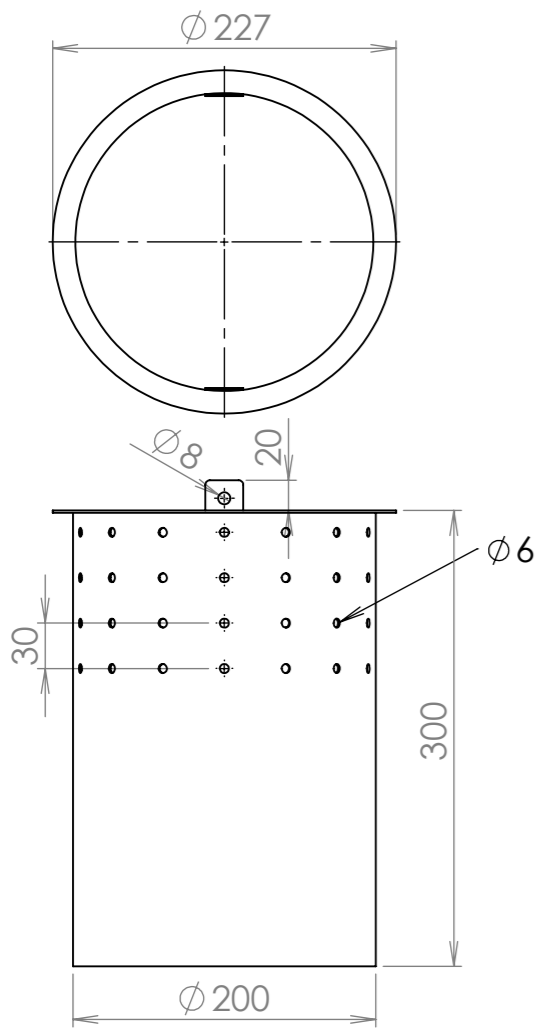
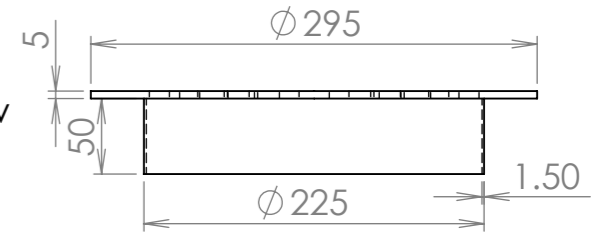

TITLE:	50-11-0009	DATE	16/08/17	BRITEX Britex Metal Products Co. Pty Ltd. ACN: 004 309 737 2 Mirra Ct, Bundoora Victoria 3083 P: 03 9466 9000 F: 03 9466 9044 britex.com.au info@britex.com.au	A3
DRAWN:	db	CHK'D			
Drawing:	SD-4456.2	APP'V'D			REVISION
UNLESS OTHERWISE SPECIFIED: DIMENSIONS ARE IN MILLIMETERS			DO NOT SCALE DRAWING	SHEET 2 OF 2	SCALE:1:5
					A