

**Sink Dropper**  
To be set below 'Slide Rails' level avoiding splashing.

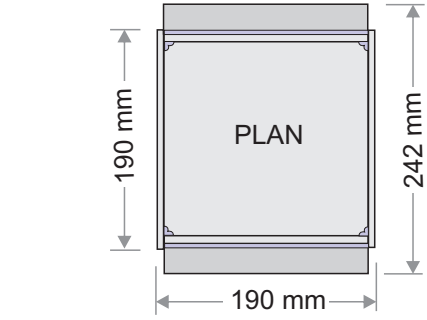

VIEW B (Internal Trap)

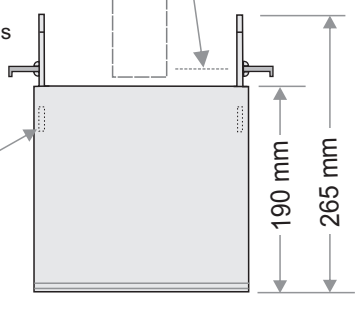
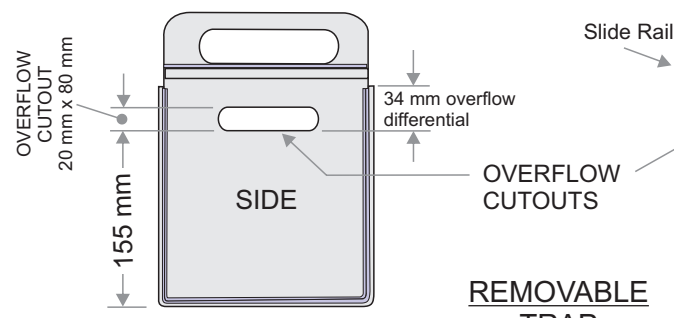

Manufactured under a quality system certified as complying with ISO 9001 by an accredited certification body.



Drawing No.SP 32	CONSTRUCTED FROM 6mm PVC PLASTIC	NOT DRAWN TO SCALE
<b>NAME</b>	<b>PLASTER / SOLIDS TRAP - BOTTOM OUTLET</b>	
	<b>CODE</b>	<b>PLTRAPBO</b> ©
	<b>COMPANY</b>	STORM PLASTICS (SA) Pty Ltd
	<b>VOLUME</b>	Outer = 24.5 L, Inner = 5.6 L to overflow cutouts.
	<b>PIPE MATERIAL</b>	Poly Vinyl Chloride - PVC
		May 2020
<b>DIMENSIONS</b>	All dimensions shown are nominal in mm and subject to change without notice.	